

SEMINATRICE

PER MT 90-125
MT_{HI} 90

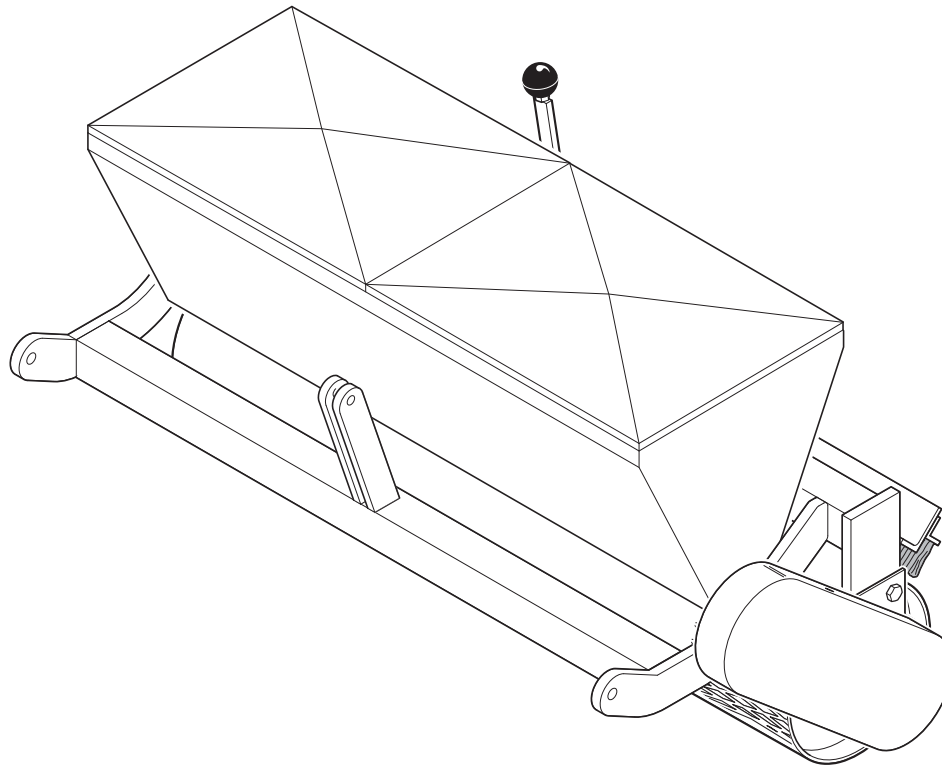

R2 s.a.s. di Rinaldi Roberto & C.

40060 Toscanella di Dozza (Bologna) Italy - Via Valsellustra, 25-29

Tel. +39.0542.672100 • Fax +39.0542.674391

CATALOGO PARTI DI RICAMBIO
SPARE PARTS CATALOGUE
CATALOGUE DE PIECES DETACHEES
ERSATZTEILKATALOG
CATALOGO DE PIEZAS DE REPUESTO

Cod. 036 rev.0

Edizione 06/2008

SIMBOLOGIA • SYMBOLS • SYMBOLES UTILISES • SYMBOLE • SIMBOLOGIA

I

Nella colonna CODICE di ogni distinta può essere presente uno di questi simboli:



Parte di ricambio momentaneamente priva di codice.

Per identificarla occorre indicare:

- Numero della tavola
- Numero di posizione
- Modello e matricola della macchina.

GB

In the CODED column of each list, you find one of following symbols:



Spare part temporarily uncoded.

To identify the part you must specify:

- Table code
- Position number
- Machine model and serial number.

F

Dans la colonne CODE de chaque liste Vous pouvez trouver un des symboles suivants:



Pièce de réchange temporairement sans code.

Pour son identification, il faut spécifier:

- Code du tableau
- Numéro de position
- Modèle et numéro de fabrique machine.

D

Die Reihe Anmerkungen jeder CODE kann eins folgender Symbole zeigen:



Ersatzteil hat vorübergehend keinen Code.

Um diesen Ersatzteil angeben zu können, müssen Sie:

- Code Tabelle
- Positionsnummer
- Maschinenmodell und -nummer.

E

La columna CÓDIGO de cada lista puede presentar uno de los símbolos siguientes:



Repuesto actualmente falto de código.

Para la identificación del repuesto es necesario indicar:

- Código tabla
- Número de posición
- Modelo y número de serie máquina.



Parte di ricambio avente ulteriori parti di ricambio interne.

Per identificare le singole parti interne occorre andare alla tavola di corrispondente denominazione.



Spare part consisting of more internal spare parts.

To find the single internal parts, please refer to the relevant description table.



Pièce de réchange comprenant des pièces de rechange à l'intérieur.

Pour l'identification de pièces individuelles, se référer au tableau descriptif correspondant.



Ersatzteil hat weitere Ersatzteile auf der Innenseite.

Für die Identifikation der einzelnen Innerteile, die entsprechende Benennungstabelle nachschlagen.



Ruesto que consta de sucesivos repuestos internos.

Para la identificación de las partes internas distintas, ver tabla descriptiva correspondiente.



Parte di ricambio con variabili dimensionali o di quantità.

Occorre specificare il modello e la matricola della macchina individuali nell'apposita targhetta.



Spare part with dimension or quantity variables.

Always specify the machine model and serial number, given in the identification plate.



Pièce détachée avec variables dimensionnelles o de quantité.

Spécifier toujours le modèle et le numéro de fabrique de la machine, donnés sur la plaque d'identification.



Ersatzteil mit variablen Maßen oder Menge.

Bitte, Modell und Fabriknummer der Maschine, die auf dem Typenschild abgedruckt sind, angeben.



Repuesto con variables dimensionales o de cantidad.

Declarar siempre el modelo y el número de serie de la máquina, que se encuentran en la tarjeta de identificación.

COME ORDINARE I RICAMBI • HOW TO ORDER SPARE PARTS • COMMANDE DES PIÈCES DÉTACHÉES • ANFRANGE VON ERSATZTEILEN • PEDIDO DE LOS REPUESTOS

Per ordinare le parti di ricambio Vi preghiamo cortesemente di fornire al Servizio Assistenza tutte le seguenti informazioni:

- Modello, tipo e numero di matricola della macchina.
- Codice, descrizione e quantità delle parti di ricambio che si intendono ordinare.

Inoltre all'ordine sarà necessario precisare:

- Ragione sociale, indirizzo completo, recapito telefonico e telefax.
- Indirizzo completo al quale spedire le parti di ricambio.
- Eventuale mezzo di trasporto/vettore da utilizzare preferenzialmente.

When ordering spare parts, please supply After Sales Service the following information:

- Machine model, type and serial number
- Code, description and quantity of the spare parts you wish to order.

In addition to what above, add also:

- Corporate name, address, phone and fax number.
- Delivery address.
- Preferential transport mean/carrier.

Pour commander les pièces de rechange nous vous prions de bien vouloir transmettre au ServiceAprès-Vente les indications suivantes:

- Modèle, type et numéro de série de la machine.
- Code, description et quantité des pièces de rechange commandées.

De plus, indiquer dans la commande:

- Nom de la société, adresse complète, numéro de téléphone et de télécopieur.
- Adresse complète pour l'expédition.
- Eventuel moyen de transport/expéditeur préférentiel.

Um Ersatzteil zu bestellen, bitten wir Sie höflichst, dem Kundendienst alle nachfolgend angeführten Angaben zu machen:

- Modell, Typ und Matrikel-Nr. der Maschine.
- Code, Beschreibung und Anzahl der Ersatzteile, die man bestellen möchte.

Außerdem sollte man bei der Bestellung angeben:

- Name der Firma, vollständige Adresse, Telefon und Faxnummer.
- Vollständige Adresse, an die Ersatzteile zu senden sind.
- Von Ihnen gewünschtes Transportmittel / Transportunternehmen.

Para el pedido de repuestos, Le rogamos se sirvan suministrar al Servicio Asistencia todas las indicaciones siguientes:

- Modelo, tipo y número de matrícula de la máquina.
- Código, descripción y cantidad de los repuestos pedido.

Además, se ruega detallar lo siguiente:

- Razón social, dirección completa, teléfono y telefax.
- Dirección completa a la que se deben enviar los repuestos.
- Eventual medio/agente de transporte que se desea utilizar.

INDICE DELLE TAVOLE • TABLE INDEX • INDEX DES TABLEAUX

01.0 CASSONETTO SEMINATRICE (SM 90)
02.0 CASSONETTO SEMINATRICE (SM 125)
03.0 MONTAGGIO RULLO POSTERIORE (SM 90)
04.0 MONTAGGIO RULLO POSTERIORE (SM 125)

SEEDER BOX (SM 90)
SEEDER BOX (SM 125)
REAR ROLLER ASSEMBLY (SM 90)
REAR ROLLER ASSEMBLY (SM 125)

CAISSON SEMOIR (SM 90)
CAISSON SEMOIR (SM 125)
MONTAGE ROULEAUX ARRIERE (SM 90)
MONTAGE ROULEAUX ARRIERE (SM 125)

TABELLEN-VERZEICHNIS • INDICE DE LAS TABLAS

01.0	KASTEN DRILLMASCHINE (SM 90)	CAJA SEMBRADORA (SM 90)
02.0	KASTEN DRILLMASCHINE (SM 125)	CAJA SEMBRADORA (SM 125)
03.0	MONTAGE HINTERE ROLLEN (SM 90)	MONTAGE RODILLOS TRASERO (SM 90)
04.0	MONTAGE HINTERE ROLLEN (SM 125)	MONTAGE RODILLOS TRASERO (SM 125)



CASSONETTO SEMINATRICE (SM 90)
SEEDER BOX (SM 90)
CAISSON SEMOIR (SM 90)
KASTEN DRILLMASCHINE (SM 90)
CAJA SEMBRADORA (SM 90)

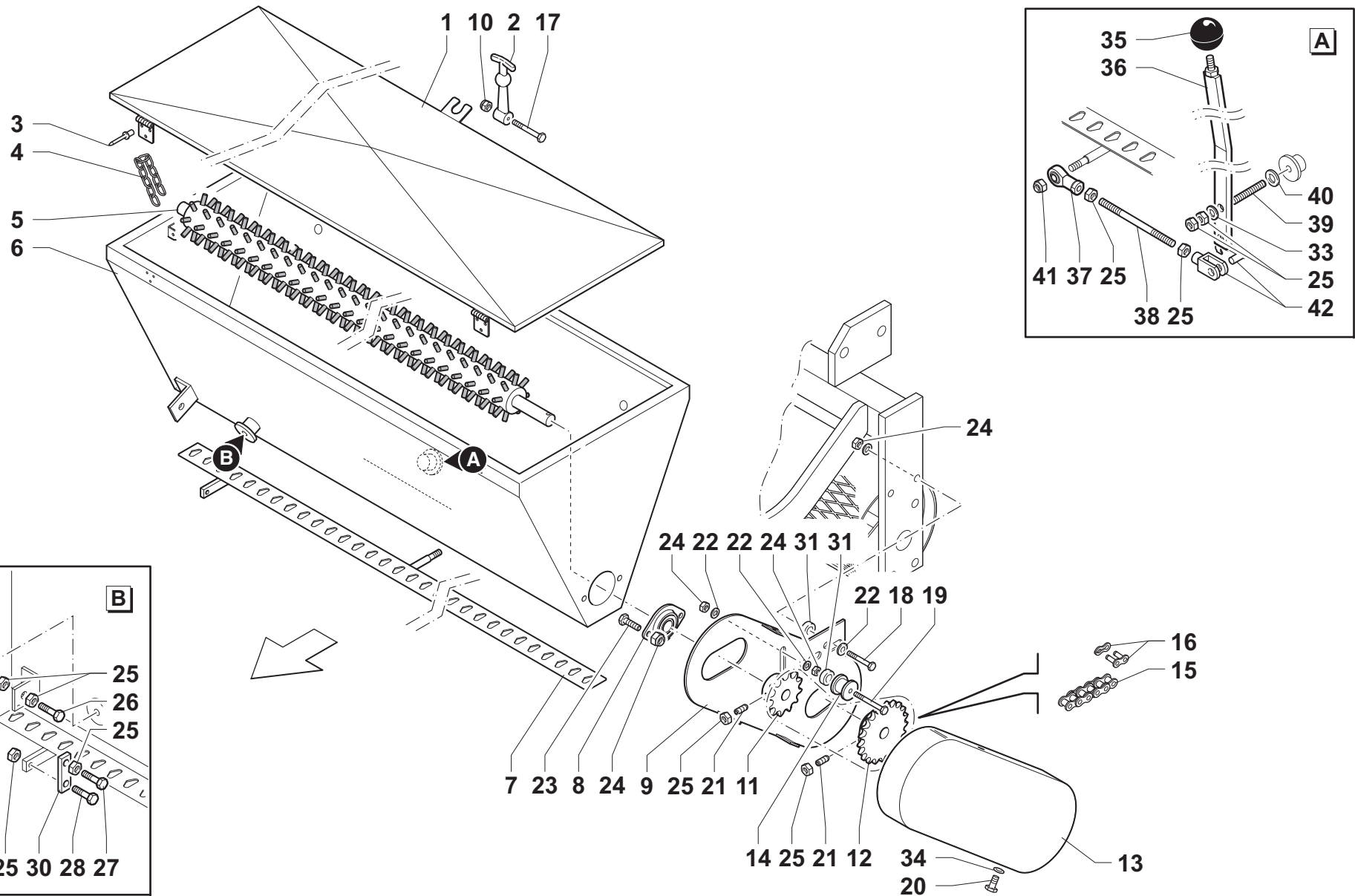

<i>Rif.</i>	<i>CODICE</i>	<i>Qty</i>	<i>Descrizione</i>	<i>Description</i>	<i>Designation</i>	<i>Benennung</i>	<i>Denominaciones</i>
1	036.002/A	1	COPERCHIO	COVER	COUVERCLE	DECKEL	TAPA
2	050.066	1	TIRANTE IN GOMMA	RUBBER TIE-ROG	TIRANT CAOUTCHOUC	GUMMI-ZUGSTANGE	TIRANTE DE GOMA
3		6	RIVETTO	RIVET	RIVET	NIETVERBINDUNG	REMACHE
4		1	CATENA	CHAIN	CHAÎNE	KETTE	CADENA
5	036.053	1	SPAZZOLA CASSONETTO	BOX BRUSH	BROSSE CAISSON	BÜRSTE KASTEN	CEPILLO CAJA
6	036.002	1	CASSONETTO SEMINATRICE	SEEDER BOX	CAISSON SEMOIR	KASTEN DRILLMASCHINE	CAJA SEMBRADORA
7	036.002/B	1	BANDELLA CASSONETTO	BOX BAR	RABAT CAISSON	KASTENBAND	BANDA CAJA
8	BUBPFL204	2	SUPPORTO	SUPPORT	SUPPORT	LAGER	SOPORTE
9	036.083	1	CARTER INTERNO CATENA	INTERNAL COVER FOR	CARTER INTERIEUR	INNERE SCHUTZABDECKUNG	CÁRTER INTERIOR CADENA
10	30.02.00.004	1	DADO AUTOBLOCCANTE	STOP NUT	ECROU DE SURETE	SPERRMUTTER	TUERCA AUTOTRABADORA
11	036.082	1	PIGNONE	PINION	PIGNON	RITZEL	PINON
12	036.081	1	CORONA	RING GEAR	COURONNE	KRANZ	CORONA
13	036.083/A	1	CARTER ESTERNO	EXTERNAL COVER FOR	CARTER EXTERIEUR	AUSSERE SCHUTZABDECKUNG	CÁRTER EXTERIOR CADENA
14	090.036	1	RULLO	ROLLER	ROULEAU	WALZE ROLLE	RODILLO
15	050.075	1	CATENA	CHAIN	CHAÎNE	KETTE	CADENA
16	050.076	1	MAGLIA DI GIUNZIONE	CHAIN JOINT	JOINT DE CHAÎNE	STECKGLIED	UNIÓN DE CADENA
17	21.0.0.04035	1	VITE	SCREW	VIS	SCHRAUBE	TORNILLO
18	20.0.0.08040	2	VITE	SCREW	VIS	SCHRAUBE	TORNILLO
19	20.0.0.08055	1	VITE	SCREW	VIS	SCHRAUBE	TORNILLO
20	21.0.0.05016	1	VITE	SCREW	VIS	SCHRAUBE	TORNILLO
21	25.2.1.08020	2	GRANO	SECURITY DOWEL	GRAIN	STIFT	PERNO DE TOPE
22	15.1.0.00.008	4	RONDELLA PIANA	PLAIN WASHER	RONDELLE PLANE	ABSTANDSRING	ARANDELA LLANA
23	21.0.0.08016	2	VITE	SCREW	VIS	SCHRAUBE	TORNILLO
24	30.02.00.008	6	DADO AUTOBLOCCANTE	STOP NUT	ECROU DE SURETE	SPERRMUTTER	TUERCA AUTOTRABADORA
25	31.02.00.0.08	10	DADO	NUT	ECROU	MUTTER	TUERCA
26	20.0.0.08030	1	VITE	SCREW	VIS	SCHRAUBE	TORNILLO
27	20.0.0.08035	1	VITE	SCREW	VIS	SCHRAUBE	TORNILLO
28	21.0.0.08025	1	VITE	SCREW	VIS	SCHRAUBE	TORNILLO
29	050.030	1	POMELLO	BALL-GRIP	POMMEAU	KUGELGRIFF	POMO
30	036.068	1	PIATTO FORATO	PLATE	PLATEAU	TELLER	DISCO
31	036.205	2	DISTANZIALE	SPACER	ENTRETOISE	ABSTANDSTUECK	SEPARADOR



MT / MTHI

Tav. 01.0



CASSONETTO SEMINATRICE (SM 90)
SEEDER BOX (SM 90)
CAISSON SEMOIR (SM 90)
KASTEN DRILLMASCHINE (SM 90)
CAJA SEMBRADORA (SM 90)

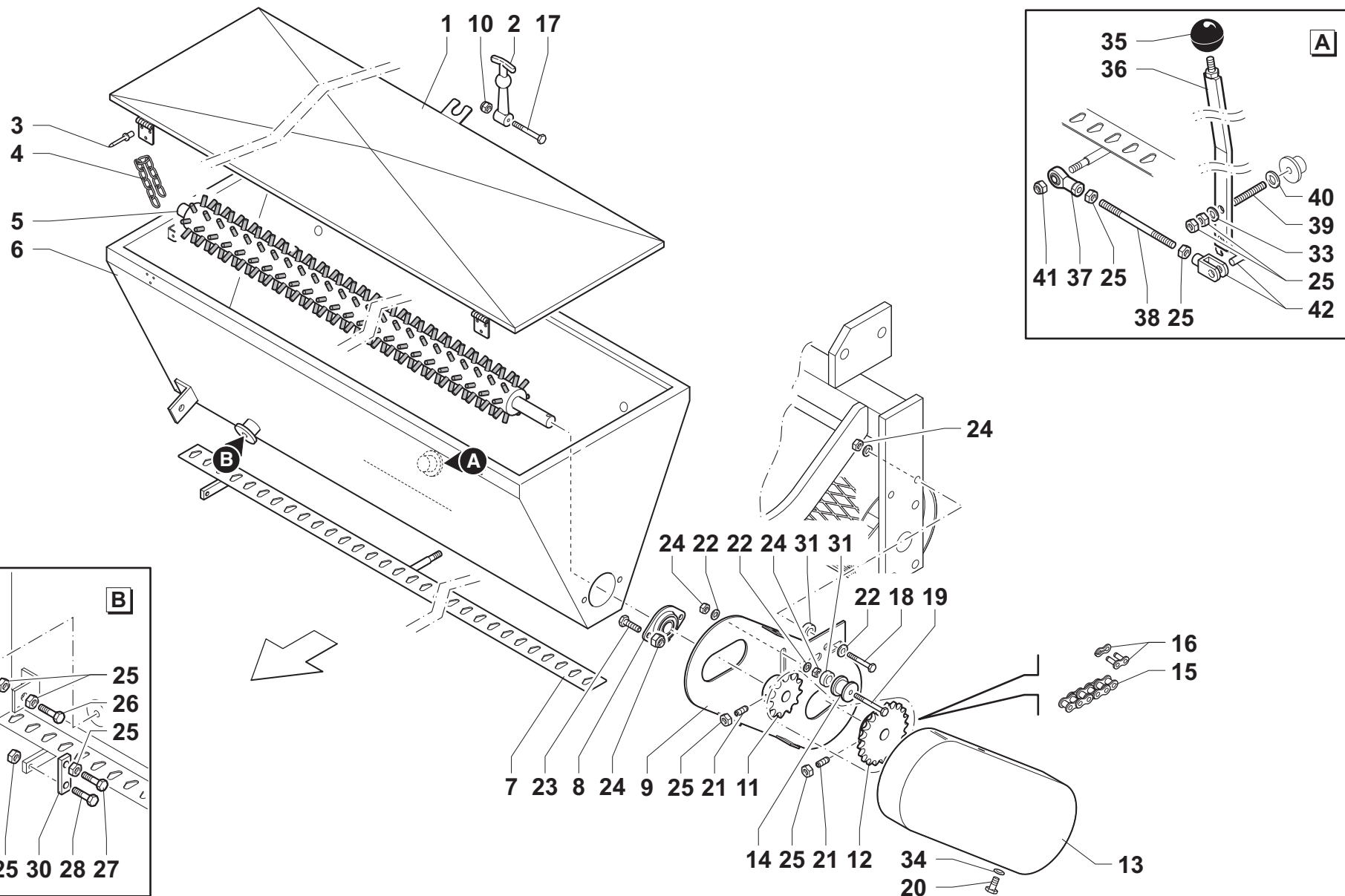

Rif.	CODICE	Qty	Descrizione	Description	Designation	Benennung	Denominaciones
32	036.066	1	CAMMA REGOLAZIONE	ADJUSTMENT CAM	CAME DE REGLAGE	EINSTELLNOCKEN	LEVA DE AJUSTE
33	050.071	2	RONDELLA TEFLON	TEFLON WASHER	RONDELLE TEFLON	TEFLON-SCHEIBE	ARANDELA TEFLON
34	15.0.0.00.005	1	RONDELLA PIANA	PLAIN WASHER	RONDELLE PLANE	ABSTANDSRING	ARANDELA LLANA
35	050.068	1	POMELLO	BALL-GRIP	POMMEAU	KUGELGRIFF	POMO
36	036.063	1	LEVA	LEVER	LEVIER	HEBEL	PALANCA
37	050.263	1	SNODO SFERICO	BALL JOINT	JOINT A ROTULE	KUGELGELENK	ARTICULACION DE BOLA
38	036.048	1	BARRA FILETTATA	THREADED BAR	BARE FILETEE	STANGE SCHRAUBEN	BARRA FILETEAR
39	26.0.0.08025	2	PRIGIONIERO	STUD	PRISONNIER	GEWINDESTIFT	PRISIONERO
40	050.072	2	RONDELLA TEFLON	TEFLON WASHER	RONDELLE TEFLON	TEFLON-SCHEIBE	ARANDELA TEFLON
41	30.02.01.008	1	DADO AUTOBLOCCANTE	STOP NUT	ECROU DE SURETE	SPERRMUTTER	TUERCA AUTOTRABADORA
42	050.069	1	FORCELLA	FORK	FOURCHE	GABEL	HORQUILLA





CASSONETTO SEMINATRICE (SM 125)
SEEDER BOX (SM 125)
CAISSON SEMOIR (SM 125)
KASTEN DRILLMASCHINE (SM 125)
CAJA SEMBRADORA (SM 125)

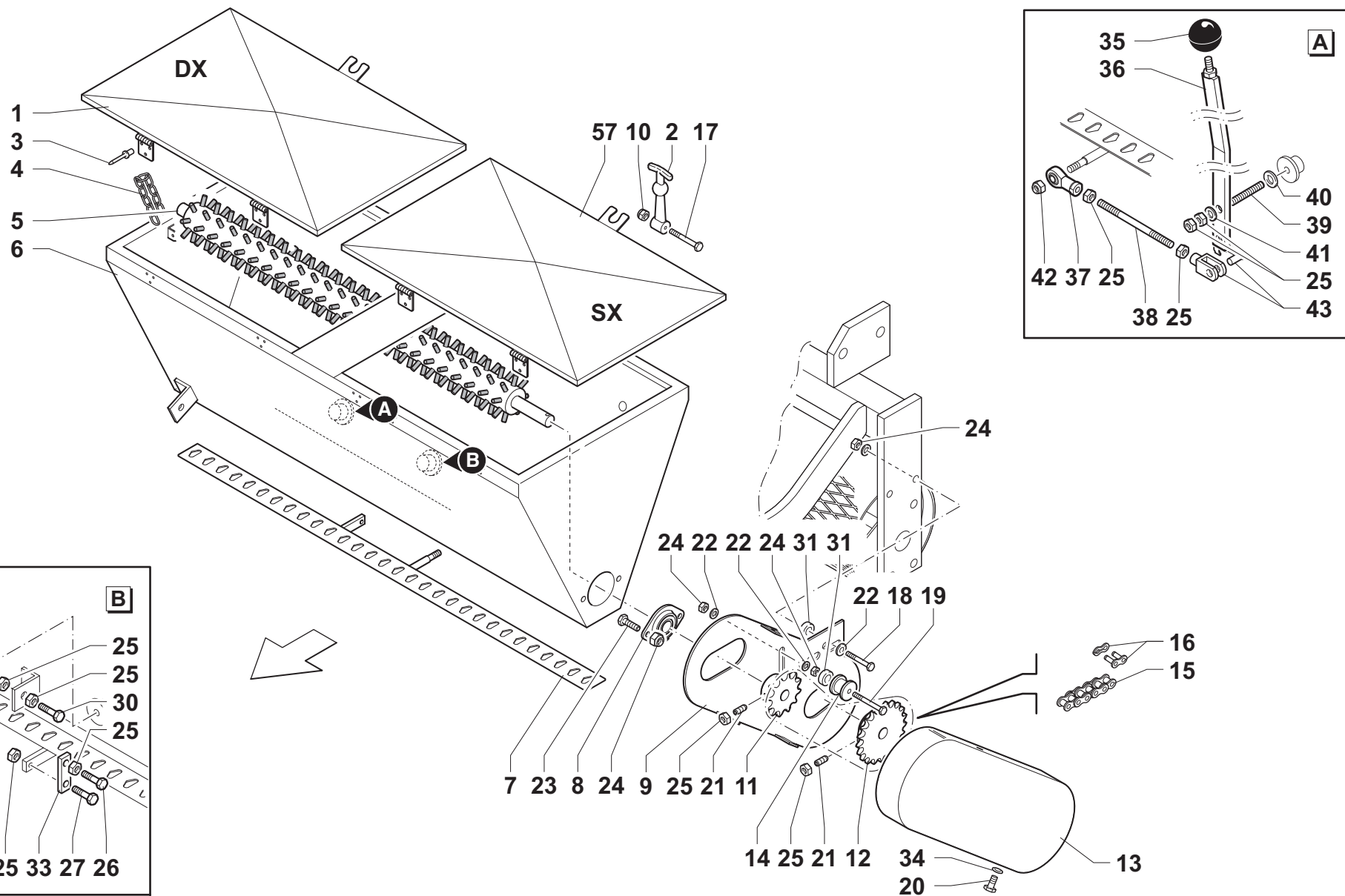

Rif.	CODICE	Qty	Descrizione	Description	Designation	Benennung	Denominaciones
1	036.006/DX	2	COPERCHIO	COVER	COUVERCLE	DECKEL	TAPA
2	050.066	2	TIRANTE IN GOMMA	RUBBER TIE-ROG	TIRANT CAOUTCHOUC	GUMMI-ZUGSTANGE	TIRANTE DE GOMA
3		12	RIVETTO	RIVET	RIVET	NIETVERBINDUNG	REMACHE
4		2	CATENA	CHAIN	CHAÎNE	KETTE	CADENA
5	036.056	1	SPAZZOLA CASSONETTO	BOX BRUSH	BROSSE CAISSON	BÜRSTE KASTEN	CEPILLO CAJA
6	036.041	1	CASSONETTO SEMINATRICE	SEEDER BOX	CAISSON SEMOIR	KASTEN DRILLMASCHINE	CAJA SEMBRADORA
7	036.006/B	1	BANDELLA CASSONETTO	BOX BAR	RABAT CAISSON	KASTENBAND	BANDA CAJA
8	BUBPFL204	2	SUPPORTO	SUPPORT	SUPPORT	LAGER	SOPORTE
9	036.083/L	1	CARTER INTERNO CATENA	INTERNAL COVER FOR	CARTER INTERIEUR	INNERE SCHUTZABDECKUNG	CÁRTER INTERIOR CADENA
10	30.02.00.004	2	DADO AUTOBLOCCANTE	STOP NUT	ECROU DE SURETE	SPERRMUTTER	TUERCA AUTOTRABADORA
11	036.082	1	PIGNONE	PINION	PIGNON	RITZEL	PINON
12	036.081	1	CORONA	RING GEAR	COURONNE	KRANZ	CORONA
13	036.084/L	1	CARTER ESTERNO	EXTERNAL COVER FOR	CARTER EXTERIEUR	AUSSERE SCHUTZABDECKUNG	CÁRTER EXTERIOR CADENA
14	090.036	1	RULLO	ROLLER	ROULEAU	WALZE ROLLE	RODILLO
15	050.075	1	CATENA	CHAIN	CHAÎNE	KETTE	CADENA
16	050.076	1	MAGLIA DI GIUNZIONE	CHAIN JOINT	JOINT DE CHAÎNE	STECKGLIED	UNIÓN DE CADENA
17	21.0.0.04035	2	VITE	SCREW	VIS	SCHRAUBE	TORNILLO
18	20.0.0.08040	2	VITE	SCREW	VIS	SCHRAUBE	TORNILLO
19	20.0.0.08055	1	VITE	SCREW	VIS	SCHRAUBE	TORNILLO
20	21.0.0.05016	1	VITE	SCREW	VIS	SCHRAUBE	TORNILLO
21	25.2.1.08020	2	GRANO	SECURITY DOWEL	GRAIN	STIFT	PERNO DE TOPE
22	15.1.0.00.008	4	RONDELLA PIANA	PLAIN WASHER	RONDELLE PLANE	ABSTANDSRING	ARANDELA LLANA
23	21.0.0.08016	2	VITE	SCREW	VIS	SCHRAUBE	TORNILLO
24	30.02.00.008	6	DADO AUTOBLOCCANTE	STOP NUT	ECROU DE SURETE	SPERRMUTTER	TUERCA AUTOTRABADORA
25	31.02.00.0.08	10	DADO	NUT	ECROU	MUTTER	TUERCA
26	20.0.0.08035	1	VITE	SCREW	VIS	SCHRAUBE	TORNILLO
27	21.0.0.08025	1	VITE	SCREW	VIS	SCHRAUBE	TORNILLO
28	036.006/SX	2	COPERCHIO	COVER	COUVERCLE	DECKEL	TAPA
29	050.030	1	POMELLO	BALL-GRIP	POMMEAU	KUGELGRIFF	POMO
30	20.0.0.08030	1	VITE	SCREW	VIS	SCHRAUBE	TORNILLO
31	036.205	2	DISTANZIALE	SPACER	ENTRETOISE	ABSTANDSTUECK	SEPARADOR



MT / MTHI

Tav. 02.0



CASSONETTO SEMINATRICE (SM 125)
SEEDER BOX (SM 125)
CAISSON SEMOIR (SM 125)
KASTEN DRILLMASCHINE (SM 125)
CAJA SEMBRADORA (SM 125)

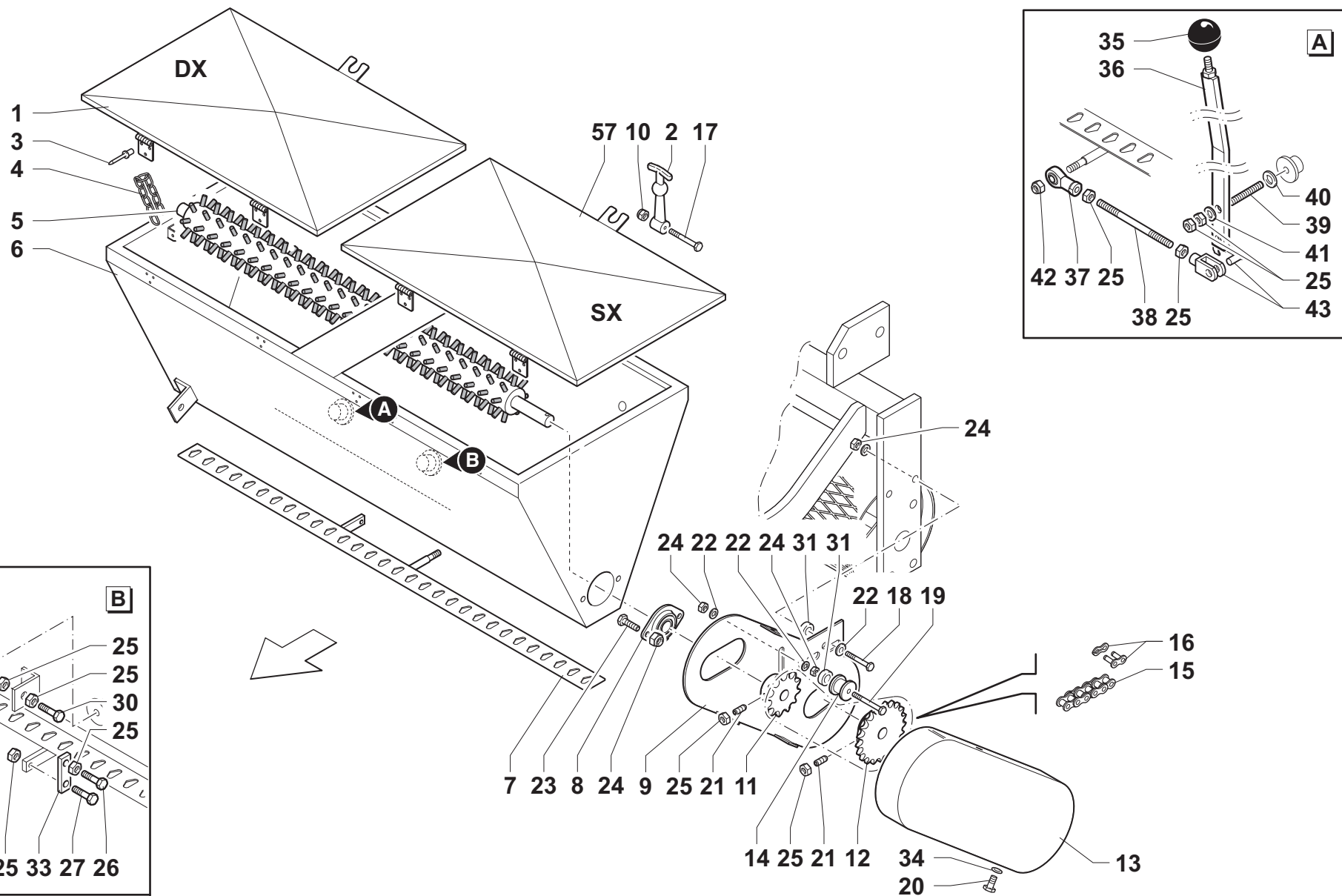



MONTAGGIO RULLO POSTERIORE (SM 90)
REAR ROLLER ASSEMBLY (SM 90)
MONTAGE ROULEAUX ARRIERE (SM 90)
MONTAGE HINTERE ROLLEN (SM 90)
MONTAGE RODILLOS TRASERO (SM 90)

MT / MTH

Tav. 03.0

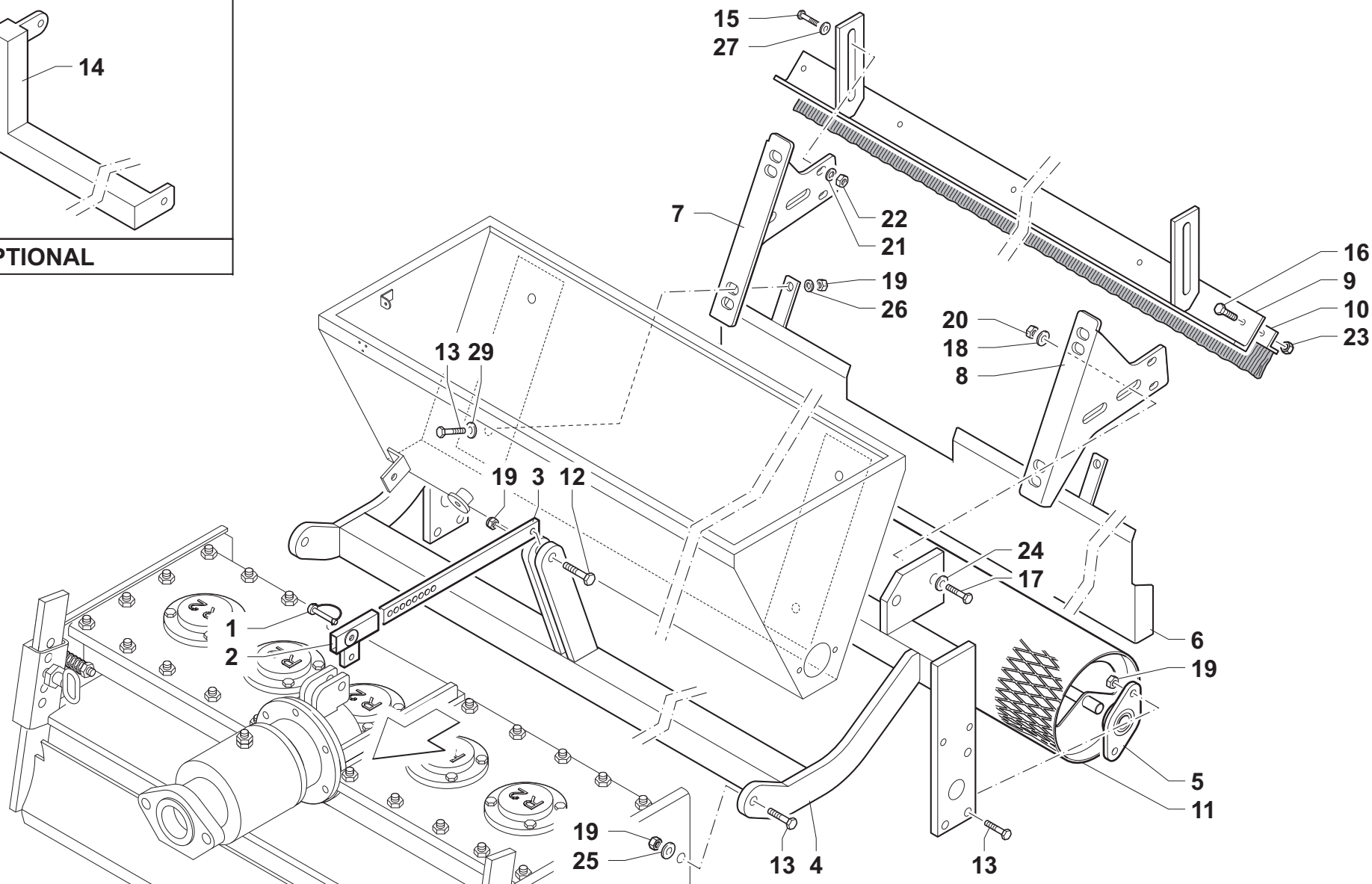
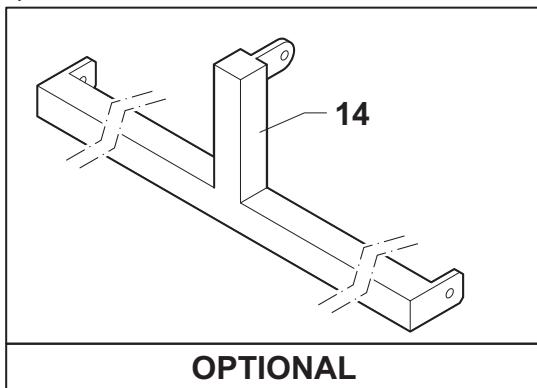

<i>Rif.</i>	<i>CODICE</i>	<i>Qty</i>	<i>Descrizione</i>	<i>Description</i>	<i>Designation</i>	<i>Benennung</i>	<i>Denominaciones</i>
1	050.004	1	COPIGLIA	COTTER PIN	GOUPILLE	SPLINT	CLAVIJA
2	000.009	1	GUIDA	GUIDE	GUIDE	FÜHRUNG	GUIA
3	036.085	1	TIRANTE	TIE ROD	TIRANT	SPANNSTANGE	TIRANTE
4	036.011	1	SUPPORTO RULLO	SUPPORT	SUPPORT	LAGER	SOPORTE
5	UCFL204	2	SUPPORTO	SUPPORT	SUPPORT	LAGER	SOPORTE
6	036.016	1	SCIVOLO PER SEME	SEED CHUTE	GLISSOIR SEMENCES	KÖRNERRUTSCHE	RAMPA SEMILLAS
7	036.080/D	1	SUPPORTO CASSONETTO DX	RIGHT BOX SUPPORT	SUPPORT COFFRE DROIT	KASTENHALTERUNG RECHTS	SOPORTE CAJA DERECHA
8	036.080/S	1	SUPPORTO CASSONETTO SX	LEFT BOX SUPPORT	SUPPORT COFFRE GAUCHE	KASTENHALTERUNG LINKS	SOPORTE CAJA IZQUIERDA
9	036.033	1	SUPPORTO SPAZZOLA	BRUSH SUPPORT	SUPPORT BROUSSE	BÜRSTENTRÄGER	SOPORTE CEPILLO
10	036.046	1	SPAZZOLA	BRUSH	BROSSE	BUERSTE	CEPILLO
11	036.023	1	RULLO	ROLLER	ROULEAU	WALZE ROLLE	RODILLO
12	21.0.0.10045	1	VITE	SCREW	VIS	SCHRAUBE	TORNILLO
13	20.0.0.10035	10	VITE	SCREW	VIS	SCHRAUBE	TORNILLO
14	036.201	1	TIMONE TRAINO	DRAWBAR	TIMON DE REMORQUAGE	ZUGSTANGE	BARRA DE ENGANCHE
15	20.0.0.08030	4	VITE	SCREW	VIS	SCHRAUBE	TORNILLO
16	21.0.0.06020	4	VITE	SCREW	VIS	SCHRAUBE	TORNILLO
17	20.0.0.12040	4	VITE	SCREW	VIS	SCHRAUBE	TORNILLO
18	15.1.0.00.012	4	RONDELLA PIANA	PLAIN WASHER	RONDELLE PLANE	ABSTANDSRING	ARANDELA LLANA
19	30.02.00.010	11	DADO AUTOBLOCCANTE	STOP NUT	ECROU DE SURETE	SPERRMUTTER	TUERCA AUTOTRABADORA
20	30.02.01.012	4	DADO AUTOBLOCCANTE	STOP NUT	ECROU DE SURETE	SPERRMUTTER	TUERCA AUTOTRABADORA
21	15.0.0.00.008	4	RONDELLA PIANA	PLAIN WASHER	RONDELLE PLANE	ABSTANDSRING	ARANDELA LLANA
22	30.02.00.008	4	DADO AUTOBLOCCANTE	STOP NUT	ECROU DE SURETE	SPERRMUTTER	TUERCA AUTOTRABADORA
23	30.02.00.006	4	DADO AUTOBLOCCANTE	STOP NUT	ECROU DE SURETE	SPERRMUTTER	TUERCA AUTOTRABADORA
24	15.0.0.00.012	4	RONDELLA PIANA	PLAIN WASHER	RONDELLE PLANE	ABSTANDSRING	ARANDELA LLANA
25	15.1.0.00.010	4	RONDELLA PIANA	PLAIN WASHER	RONDELLE PLANE	ABSTANDSRING	ARANDELA LLANA
26	15.0.0.00.010	4	RONDELLA PIANA	PLAIN WASHER	RONDELLE PLANE	ABSTANDSRING	ARANDELA LLANA
27	15.1.0.00.008	4	RONDELLA PIANA	PLAIN WASHER	RONDELLE PLANE	ABSTANDSRING	ARANDELA LLANA



MT / MTHI

Tav. 03.0



MONTAGGIO RULLO POSTERIORE (SM 125)
REAR ROLLER ASSEMBLY (SM 125)
MONTAGE ROULEAUX ARRIERE (SM 125)
MONTAGE HINTERE ROLLEN (SM 125)
MONTAGE RODILLOS TRASERO (SM 125)

MT / MTH

Tav. 04.0

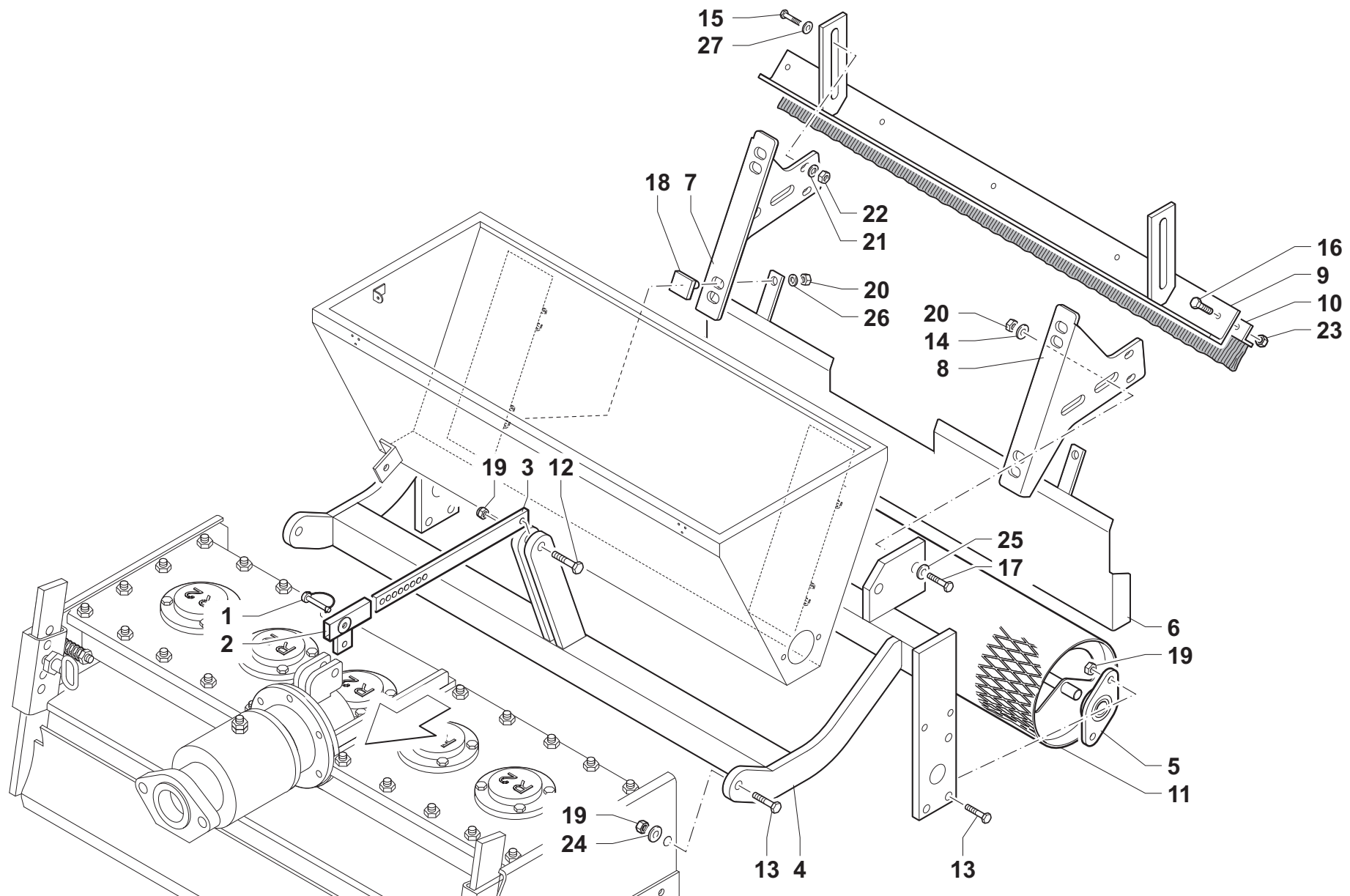

<i>Rif.</i>	<i>CODICE</i>	<i>Qty</i>	<i>Descrizione</i>	<i>Description</i>	<i>Designation</i>	<i>Benennung</i>	<i>Denominaciones</i>
1	050.004	1	COPIGLIA	COTTER PIN	GOUPILLE	SPLINT	CLAVIJA
2	000.009	1	GUIDA	GUIDE	GUIDE	FÜHRUNG	GUIA
3	036.085	1	TIRANTE	TIE ROD	TIRANT	SPANNSTANGE	TIRANTE
4	036.018	1	SUPPORTO RULLO	SUPPORT	SUPPORT	LAGER	SOPORTE
5	UCFL204	2	SUPPORTO	SUPPORT	SUPPORT	LAGER	SOPORTE
6	036.019	1	SCIVOLO PER SEME	SEED CHUTE	GLISSOIR SEMENCES	KÖRNERRUTSCHE	RAMPA SEMILLAS
7	036.080/D	1	SUPPORTO CASSONETTO DX	RIGHT BOX SUPPORT	SUPPORT COFFRE DROIT	KASTENHALTERUNG RECHTS	SOPORTE CAJA DERECHA
8	036.080/S	1	SUPPORTO CASSONETTO SX	LEFT BOX SUPPORT	SUPPORT COFFRE GAUCHE	KASTENHALTERUNG LINKS	SOPORTE CAJA IZQUIERDA
9	036.100	1	SUPPORTO SPAZZOLA	BRUSH SUPPORT	SUPPORT BROUSSE	BÜRSTENTRÄGER	SOPORTE CEPILLO
10	036.050	1	SPAZZOLA	BRUSH	BROSSE	BUERSTE	CEPILLO
11	036.099	1	RULLO	ROLLER	ROULEAU	WALZE ROLLE	RODILLO
12	21.0.0.10045	1	VITE	SCREW	VIS	SCHRAUBE	TORNILLO
13	20.0.0.10035	6	VITE	SCREW	VIS	SCHRAUBE	TORNILLO
14	15.1.0.00.012	4	RONDELLA PIANA	PLAIN WASHER	RONDELLE PLANE	ABSTANDSRING	ARANDELA LLANA
15	20.0.0.08030	4	VITE	SCREW	VIS	SCHRAUBE	TORNILLO
16	21.0.0.06020	4	VITE	SCREW	VIS	SCHRAUBE	TORNILLO
17	20.0.0.12040	4	VITE	SCREW	VIS	SCHRAUBE	TORNILLO
18	036.086	4	PIATTO	PLATE	PLATEAU	TELLER	DISCO
19	30.02.00.010	7	DADO AUTOBLOCCANTE	STOP NUT	ECROU DE SURETE	SPERRMUTTER	TUERCA AUTOTRABADORA
20	30.02.01.012	8	DADO AUTOBLOCCANTE	STOP NUT	ECROU DE SURETE	SPERRMUTTER	TUERCA AUTOTRABADORA
21	15.0.0.00.008	4	RONDELLA PIANA	PLAIN WASHER	RONDELLE PLANE	ABSTANDSRING	ARANDELA LLANA
22	30.02.00.008	4	DADO AUTOBLOCCANTE	STOP NUT	ECROU DE SURETE	SPERRMUTTER	TUERCA AUTOTRABADORA
23	30.02.00.006	4	DADO AUTOBLOCCANTE	STOP NUT	ECROU DE SURETE	SPERRMUTTER	TUERCA AUTOTRABADORA
24	15.1.0.00.010	2	RONDELLA PIANA	PLAIN WASHER	RONDELLE PLANE	ABSTANDSRING	ARANDELA LLANA
25	15.0.0.00.012	4	RONDELLA PIANA	PLAIN WASHER	RONDELLE PLANE	ABSTANDSRING	ARANDELA LLANA
26	15.0.0.00.010	4	RONDELLA PIANA	PLAIN WASHER	RONDELLE PLANE	ABSTANDSRING	ARANDELA LLANA
27	15.1.0.00.008	4	RONDELLA PIANA	PLAIN WASHER	RONDELLE PLANE	ABSTANDSRING	ARANDELA LLANA

